

GETRAG Transmission Notes

The 5-Speed GETRAG transmission offers higher-speed performance (with superior highway gas mileage) from your Opel.

The GETRAG is imported in batches, so they are offered on a first-come first-serve basis (to clients who have placed a reservation).

Options include good used, or “rebuilt” condition GETRAGS (offered as part #8038, #8038R or the #8073 with conversion kit).

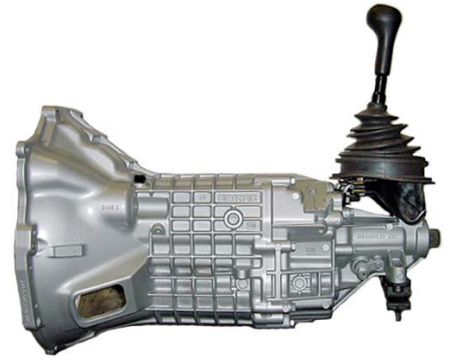

GETRAG Service Parts

Opel GT Source offers maintenance parts for the GETRAG.

These can be viewed individually on the Opel GT Source website.

- 8058 Rear Seal, 5 speed Getrag
- 8060 Front Seal, 5 speed Getrag
- 8066 Shifter Pivot, 5 speed Getrag
- 8074 Seal, 5 Speed Shifter Shaft
- 8076 GETRAG 5 Speed Reverse Light Switch

GETRAG Installation Parts

Opel GT Source also offers a number of parts required for installation of a GETRAG into a classic Opel GT (or Manta).

These can be viewed individually on the Opel GT Source website.

- 7011 U-Joint Lock Plates
- 8014/5 Speedometer Cable, Opel GT w/ Getrag 5 Speed
- 8020 GT Shift Boot
- 8028 Speedometer Cable Right-Angle Adaptor
- 8047-5 Black Plastic 5 speed shifter knob
- 8047M5 Metal Shift Knob, 5-Speed
- 8048 Getrag 5 Speed Mount, aftermarket “stiffer” style
- 8054 Driveshaft for Getrag 5 speed, GT w/ spring
- 8055 Driveshaft for Getrag 5 speed, Manta/ 1900.
- 8059 Thrust Spring, for 5 speed driveshaft
- 8068 5 Speed dust shield to bellhousing
- 8079 Synthetic Gear Oil

- conversion 5speed conversion kit for 4 speed, Opel GT
- 5spbrkt 5 speed support brackets to block, pair (used)
- 5link Shifter + Linkage kit
- 5splink Modification to 5 speed linkage for GT
- 5spmnt Modified Transmission mount bracket

GETRAG Adaptations

Installation of a GETRAG also requires some hardware alterations.

For the manual transmission GT, this includes adaptations of some transmission related hardware (*illustrated on next page*).

Early model 1968 to 1970 GT’s originally equipped with a manual transmission also require a “later” W=1062 gradient speedometer.

For Manta/Ascona, a custom trans cross-member bracket is required.

All automatic transmission Opels also require a set of clutch parts, including firewall hardware, pedals, cable, flywheel, and a clutch set. (*A/T driveshafts can also be re-sized to fit the GETRAG*).

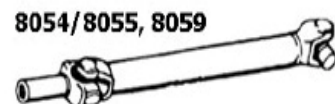
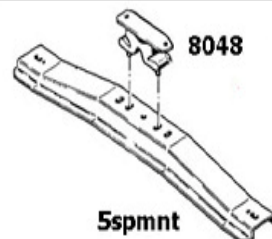
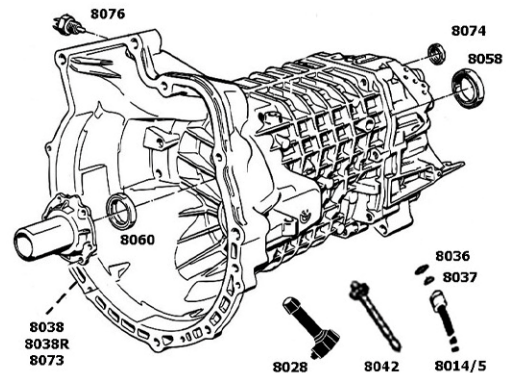

GETRAG parts and transmissions are subject to availability.

Back orders are suggested

GETRAG Transmission Notes

The GETRAG 240 transmission was originally installed in European Opels of the 1980's.

(It also shares internal parts with BMW 3-series GETRAG models from 1977 to 1983)

Installation of a GETRAG transmission into a classic Opel requires a few part adaptations and hardware alterations.

Some are shown on a layout here.

Lubricant & Seals

Opel GT Source offers case seals and lubricant
See Parts: #8058, #8060, #8074, #8079



Shifter and Linkage

Opel GT source offers a choice of custom alteration of original GETRAG linkage, or a new linkage kit w/knob
See parts: #5splink, #5link, #8020, #8047-5, #8047M5



Driveshaft and Thrust Spring

Opel GT source offers a choice of custom alteration of original Opel A/T driveshafts, or a new driveshaft
See parts: #8054, #8055, #8059, #7011

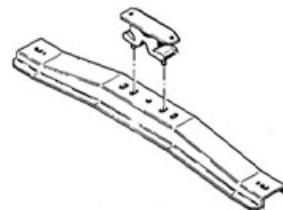

Transmission Bracket and Mount

Opel GT source offers a GETRAG transmission mount (bracket requires drilling of 2 holes & remount at auto trans underbody holes). See parts: #8048, 5spmnt
Note: Manta install requires additional adaptation

Additional Hardware*

Clutch Arm Boot
Reverse Switch
Dust Shield
Side Brackets
Clutch Spring Extension (3")
Larger Flywheel & Clutch (*optional*)

See Parts: #8021, #8068, #5spbbrkt, #8076, #8080, #8081

**May require modifications*



Speedometer Drive Gear, Cable, Adaptor, Seals

Opel GT Source offers a speedometer drive gear, as well as an adaptor and speedometer cable.
These work with a W=1062 gradient speedometer (*originally installed on 1971-73 and auto trans GT's*).
See parts: #8042, #8028, #8014/5, #8036, #8037