

“Split Lens” Tail Light Notes

1973 Opel GT Taillights

Opel GT's manufactured after January 1, 1973 (following serial number OY07NC-3100995), had a redesigned rear taillight display.

On these Opel GT rear lenses, the turn signal and brake lights were combined in the outer housings, and the reverse light was relocated from the lower panel to the round red/white-center (inner) lenses.

New Reproduction “Split” Lenses

These are now available for sale, in an original amber/red design as part #5005/6. They include the original-style metal plate and mount up to the original mount holes. These are mounted using rubber gaskets, and the housing is attached to the body using #5010 gaskets.

(We also offer a limited quantity in an all-red design, as part #5005/7).

Hardware

“Split Lens” taillight housings on the 1973 Opel GT are similar (but not identical) to the design originally installed on the 1971-1975 Opel Manta.

(Opel Manta housings can be installed on the 1973 GT, if three “hex-head” mount studs and nuts are removed and replaced with 3 “threaded “mount screws”).

Bulbs are installed as indicated at right.

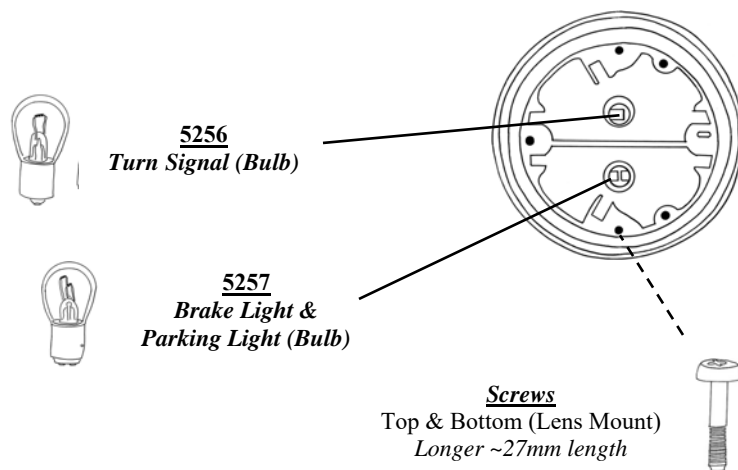
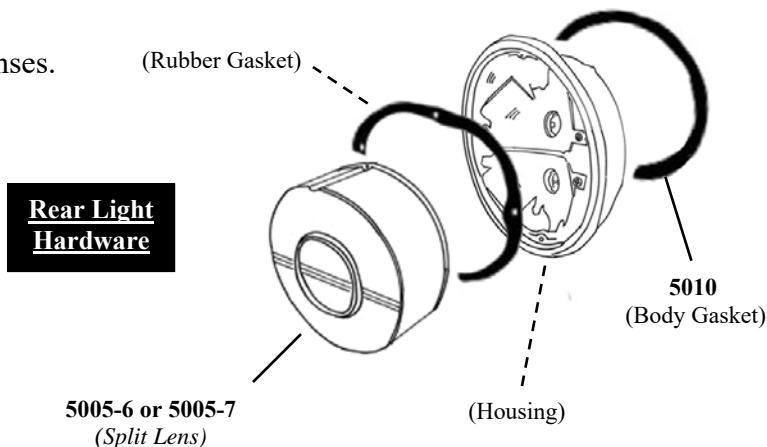
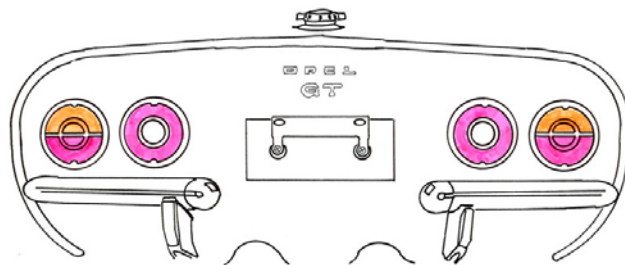

Note: Opel Manta 1971-1975 Wiring

Opel Mantas had a different wiring harness and a different rear light wire color scheme.

Brake Light wires were Black/Red

Park Light wires were Gray/Green

Turn Signals (passenger side) used Black/Green wires

Turn Signals (driver's side) used Black/White wires

Wire Connections: Rear View (1973 Opel GT)

